



ALFAZAL ENGINEERING

Manufacturer of Electrical, Mechanical Construction Material
Services and General Order Supplier

Company Profile



- ◆ Siemens Components Authorized Dealer Pakistan
- ◆ Manufacturer and Supplier of Electrical Construction Installation Material.
- ◆ Panels DB,s Junction Box Components
- ◆ Cable Tray Ladder Perforated Mesh
- ◆ Unistrut Channel Profile Accessories
- ◆ Lighting Poles Tower Structures
- ◆ Earthing Accessories Copper Rod Earth Pit Material Complete Solution
- ◆ Air Field Lighting Accessories
- ◆ Cable Glands Lugs Tags Sleeves
- ◆ Cable Drum Jack Cable Rollers
- ◆ And General Order Supplier.



www.alfazalengineering.com

ALFAZAL ENGINEERING

Company Introduction

Al-Fazal Engineering is Authorized Dealer of Siemens Components supply and Services also we are electrical construction material manufacturing company (Power Engineering is our Sister Company),

The company boost a highly coordinating team of aspiring diligent and experienced engineers with all type of plants machines and equipment's. The company has shown remarkable progress ever since in inception the company has gone from strength, thanks largely given to its commitment to uncompromised quality, speedy progress, relentless efficiency absolute customer satisfaction.

Precisely delivering total satisfactions wrapped in quality is to all about the company.

The expertise and skills of genuine group of engineers with many years of exuberant professional experience in the preparation of preliminary technical and economical feasibility study, investigation evaluation

We seek to serve and satisfy clients through prompt and efficient response.

Our objectives are:

1-To provide quality products accompanied with high quality of customer service.

2- To understand our customers' needs and endeavor to meet their requirements,

Our Products

- 1- Siemens Low Voltage Components, Circuit Breakers, Contactors PLC, Control Instruments, Motors and Drives , ON /OFF switches Overload relays
- 2- Cable Tray Hot Dip Galvanized / powder coated / GI / SS all type of cable ladders, Perforated, Stainless Steel SS Mesh.
- 3- Earthing Material Earth Rods, Clamps, Copper strip Bus Bars, Air Terminals and Pre-cast RCC Earthing Pits , Test Points , Marshaling points ,Cad Welding Lightning Protection Air Terminal Spike Bolts Base Maxi Clamp etc.
- 4- Conduit and conduit clamps, saddles , PVC Metal End Bush, different fixing arrangements , Per fabricated Scaffolding Portable Rolling Towers Platform
- 5- Unistrut Channels made of rolling forming machinery and other customized requirements with Spring Nut Bolts Hot Dip Galvanized Perforated Angle iron Channels solar support structure roof hanging threading rods anchor bolts.

- 6- Cable Accessories, Cable Glands, Lugs, Cable Tags , underground cable markers
Core Marker Sleeve SS PVC Tag Hot Core Marking Machine clamping.
- 7- Air Field Lighting Sign Boards, DMB ,Guidance Sign, Bay Designation
Sign Board , edge plates transformer housing and other hardware.
- 8- Steel Sports structures, Grid Station Structures, Transformer cable supports
HV MV cable Clamps , Trefoil clamps Gen Set, Steel Grating Manhole covers.
- 9- Cable Drum Jack hydraulic and screw type and cable rollers Caution Tape
- 10- Street Lighting Poles , Solar poles ,structural towers , overhead line towers
conical octagonal (hydraulic set up for cold reducing of pipe). J Bolts etc
- 11- We are Manufacturer of LT Panels Lighting Distribution boards with auto ON /
OFF control circuit in door out door type, ATS Panels , Battery Chargers Solar
Combiner, Bus Bars Marshaling Panels, Auto Manual Change Over Panels,
Junction Box weather proof ,CP System Panels, Lighting pole Junction Boxes.

Services Provider

- Installation of Cable Tray with support, Switchgear, Battery Banks
- Installation, testing & commissioning of Generating Sets
- Installation, testing & commissioning of Control & Protection panels
- MV/LV Control Cable laying & termination
- Installation, testing & commissioning of MV/LV panels
- Complete installation of EARTHING SYSTEMS
- Skilled labor supply Electricians, Fabricators, Masons

Our Aims.

- ◆ Employees: safety at work, training, development diversity.
- ◆ Client satisfaction, continuous improvement of its products' technical performance and services quality.
- ◆ Economic performance: operating margin, free cash flow, return on assets, level of investments
- ◆ Environmental policy: end-of-life tire recovery, number of sites with a certified environmental management system

Our Major Client List

- ❖ Engro Fertilizer Daharki
- ❖ Fuji Fertilizer Company Limited.
- ❖ Fatima Fertilizer.
- ❖ Engro polymer.
- ❖ EPRF Enar Petroleum Refining Facility
- ❖ ABB Pakistan
- ❖ MOL Pakistan
- ❖ Descon
- ❖ Dewan Petroleum (Pvt) Ltd
- ❖ Sui Northern Gas Pipeline Limited
- ❖ KRL (PSM) Limited
- ❖ Siemens Engineering Pakistan
- ❖ Al Bario Engineering (pvt) Limited
- ❖ State Bank of Pakistan.
- ❖ Flowtronix (PVT) Ltd.
- ❖ Civil Aviation Authority.
- ❖ Combine Textile Limited.
- ❖ Atlas Power Project Sheikhpura.
- ❖ Tapal Energy.
- ❖ AES Lalpir Power Plant.
- ❖ Pak Suzuki.
- ❖ OGDCL
- ❖ Areva / Schneider Pakistan.
- ❖ KICT Karachi International Terminal.
- ❖ Orient Pakistan.
- ❖ Awan Support Industries.

Some Test Reports for Quality Check & Quality Assurance

KARACHI SHIPYARD & ENGINEERING WORKS LTD.
 Central Laboratories
 (Chemical Composition Test Certificate)
 Doc. No.: Lab/FM/002
 Rev No. 01

Date: 14-01-2015

Subject: Copper Plate, 5x50mm.
 Customer: M/s Al-Fazal Engineering
 Order No: 6091 Lab Ref. No./C/L: 019/2015

S. No.	Description of Results	%
1	Copper (Cu)	99.93
1		1

KARACHI SHIPYARD & ENG. WORKS LIMITED
 LABORATORIES
 (Structural Engineering Test Certificate)
 Date: 21-2-2010

Subject: Galvanized Cable Tray
 Customer: M/s Al-Fazal Engineering
 Order No: LT-8822 Laboratory Ref. No: 8822/2010

S.No.	Description of Results	%
1	Name of Sample	Cable Tray
2	Project Name	Port Development Gas in Division Engineering
3	Flange type Cable Ladder	Common Area
4	Height	150 mm
5	Thickness of Plate	1.5 mm
6	Color of Cable	Galvanized Metal
7	Test type	Load Test
8	Load	900 kgs
9	Observation	Applied Test type Load on above mentioned Sample found No change.
10	Remarks	Found Satisfactory.

STRUCTURAL ENGINEERING DIVISION 24675
 Test Floor Laboratory
 Department of Civil Engineering
 University of Engineering and Technology Lahore, 54890
 Pakistan. Ph: 97-42-99029202

Ref: CED/TEL/01/29596 Dated: 26-01-10

To: M/S Al-Fazal Engineering Lahore

Subject: UNI-STUD CHANNEL FOR LOAD TEST (Page-1 of 1)

Reference to your letter No. ALF-18-01-2015, dated 25.01.2015 on the subject cited above. One Uni-Stud Channel for load as received by us test has been tested and the results are tabulated below.

Load (N)	0.0	200	400	600	800	1000	2000	3000	4000	5000	4000	3000	2000
Deflection (mm)	0.51	0.97	1.04	1.64	1.87	1.47	1.50	1.52	1.52	2.75	3.05	3.01	
Remarks										Ultimate load			

Curve between load & Deflection

UNISTRUT CHANNEL LOAD BEARING CAPACITY TEST

For: M/s Al-Fazal Engineering
 Test Floor Laboratory
 UET Lahore, Pakistan.
 M. Nadeem

A L - F A Z A L - E N G I N E E R I N G

Perforated Cable Tray

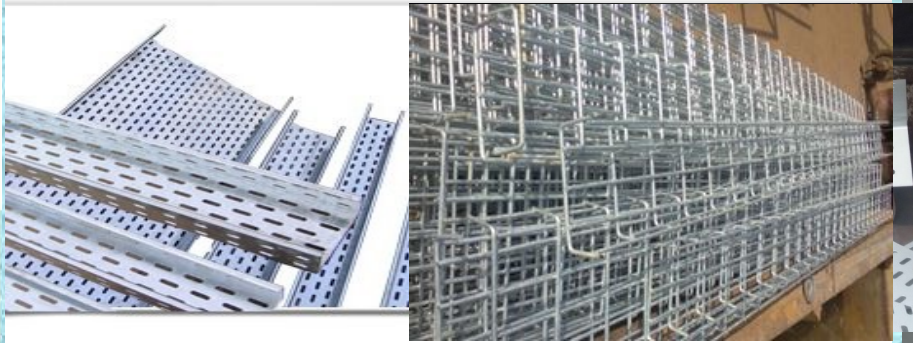

Part No	Width (W)	Height (H)	Size (MM)	Size (Inch)
P101	50MM	25MM	50x25MM	2"x1"
P102	50MM	50MM	50x50MM	2"x2"
P103	75MM	50MM	75x50MM	3"x2"
P104	75MM	75MM	75x75MM	3"x3"
P105	100MM	50MM	100x50MM	4"x2"
P106	100MM	75MM	100x75MM	4"x3"
P107	100MM	100MM	100x100MM	4"x4"
P108	150MM	75MM	150x75MM	6"x3"
P109	150MM	100MM	150x100MM	6"x4"
P110	175MM	75MM	175x75MM	7"x3"
P111	175MM	100MM	175x100MM	7"x4"
P112	200MM	75MM	200x75MM	8"x3"
P113	200MM	100MM	200x100MM	8"x4"
P114	225MM	75MM	225x75MM	9"x3"
P115	225MM	100MM	225x100MM	9"x4"
P116	250MM	75MM	250x75MM	10"x3"
P117	250MM	100MM	250x100MM	10"x4"
P118	300MM	75MM	300x75MM	12"x3"
P119	300MM	100MM	300x100MM	12"x4"
P120	450MM	75MM	450x75MM	18"x3"
P121	450MM	100MM	450x100MM	18"x4"
P122	600MM	75MM	600x75MM	24"x3"
P123	600MM	100MM	600x100MM	24"x4"
P124	800MM	100MM	800x100MM	32"x4"
P125	800MM	150MM	800x150MM	32"x6"

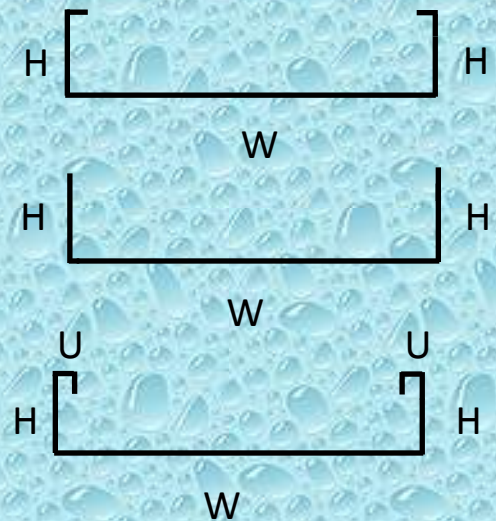

Any Type any Size

- ◆ Hot Dip Galvanized Zinc Coated .
- ◆ GI Sheet Cable Tray .
- ◆ Powder Coated color as per requirement .
- ◆ Mesh Type

We can fabricate any type and any size with accessories.as per client requirement.



NOTE: Cable Tray Accessories Cover , Cover Clamps Joints Plates and Carriage Bolts also

Ladder Cable Tray & Cable Mesh



Part No	Width(W)	Height(H)	Size(MM)	Size (Inch)
P130	100MM	75MM	100x75MM	4"x3"
P131	100MM	100MM	100x100MM	4"x4"
P132	150MM	75MM	150x75MM	6"x3"
P133	150MM	100MM	150x100MM	6"x4"
P134	175MM	75MM	175x75MM	7"x3"
P135	175MM	100MM	175x100MM	7"x4"
P136	200MM	75MM	200x75MM	8"x3"
P137	200MM	100MM	200x100MM	8"x4"
P138	225MM	75MM	225x75MM	9"x3"
P139	225MM	100MM	225x100MM	9"x4"
P140	250MM	75MM	250x75MM	10"x3"
P141	250MM	100MM	250x100MM	10"x4"
P142	300MM	75MM	300x75MM	12"x3"
P143	300MM	100MM	300x100MM	12"x4"
P144	450MM	75MM	450x75MM	18"x3"
P145	450MM	100MM	450x100MM	18"x4"
P146	600MM	75MM	600x75MM	24"x3"
P147	600MM	100MM	600x100MM	24"x4"
P148	600MM	125MM	600x125MM	24"x5"
P149	600MM	150MM	600x150MM	24"x6"
P150	800MM	100MM	800x100MM	32"x4"
P151	800MM	125MM	800x125MM	32"x5"
P152	800MM	150MM	800x150MM	32"x6"
P153	900MM	100MM	900x100MM	36"x4"
P154	900MM	125MM	900x125MM	36"x5"
P155	900MM	150MM	900x150MM	36"x6"

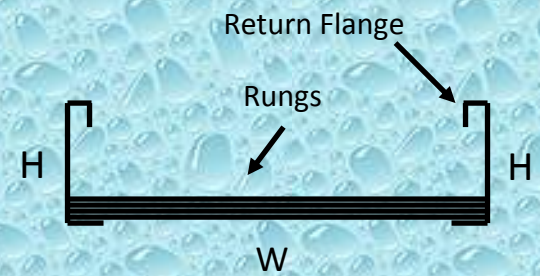
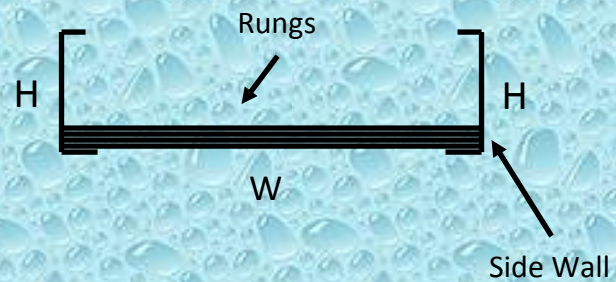

Any Type any Size of

- ◆ Hot Dip Galvanized Zinc Coated .
- ◆ GI Sheet Cable Tray .
- ◆ Powder Coated color as per requirement .
- ◆ Mesh Type

We can fabricate any type and any size with accessories as per client requirement.

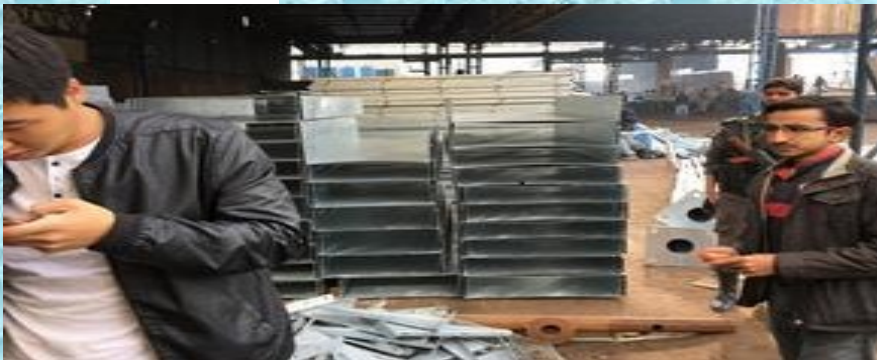

NOTE: Cable Tray Accessories Cover , Cover Clamps Joints Plates and Carriage Bolts also

A L - F A Z A L - E N G I N E E R I N G

24/07/2008

Unistrut Channel Profile and Accessories

Made of Automatic CNC Rolling Forming Machinery for Solar and General Use

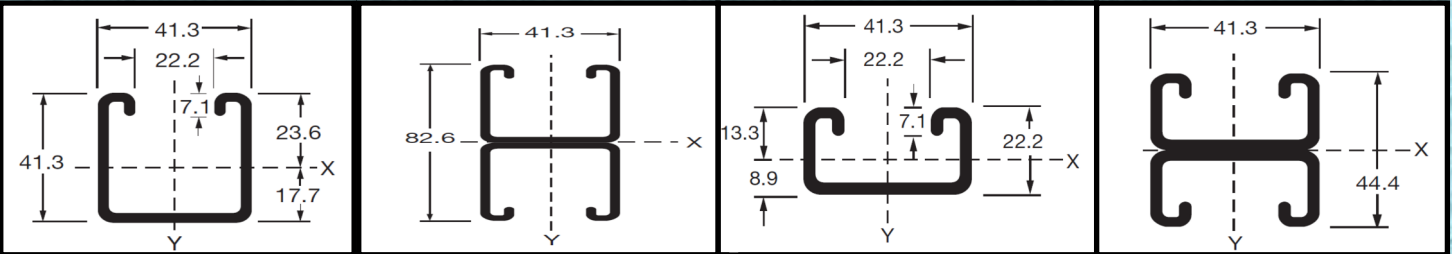

41.3mm x41.3mm Single and Double Solid

41.3mm x22.3mm Single and Double Solid

SR.N	Size	Thickness	Finish	Length	Hot Dip Galvanized
1	41.3mm X 41.3mm	1.2 MM	Hot Dip Galvanized	1 Mtr	
		1.5 MM	Powder Coat	2 Mtr	
		2.0 MM	MS (Mild Steel) Black	3 Mtr	
		2.3 MM	GI (Pre Galvanized) SS (Stainless Steel)	6 Mtr	
2	41.3mm X 22.3mm	1.2 MM	Hot Dip Galvanized	1 Mtr	
		1.5 MM	Powder Coat	2 Mtr	
		2.0 MM	MS (Mild Steel) Black	3 Mtr	
		2.3 MM	GI (Pre Galvanized)	6 Mtr	

A L - F A Z A L - E N G I N E E R I N G

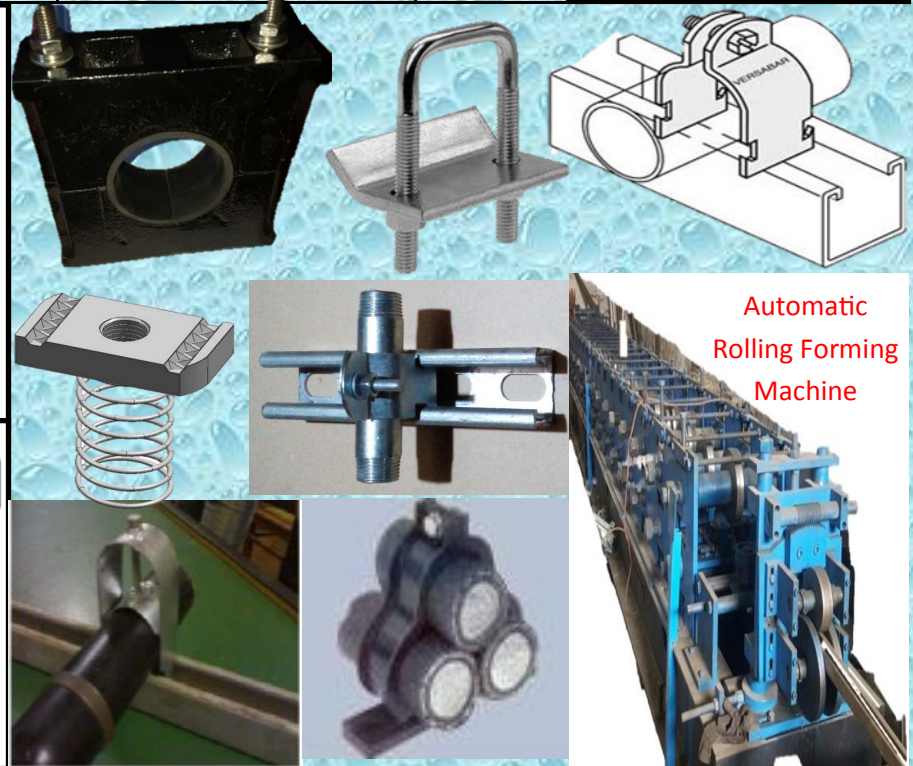
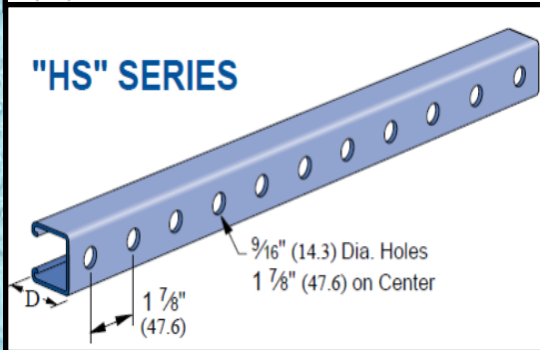
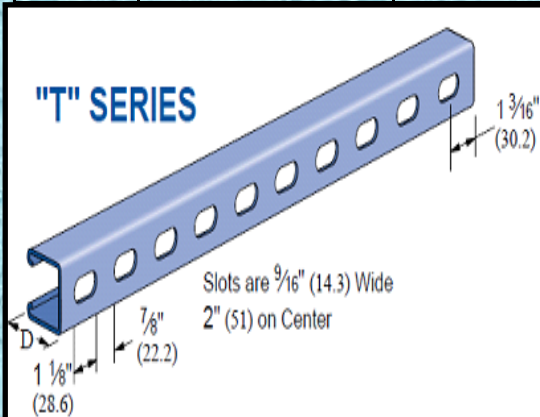

Note: 10,000 Meter Per Day Manufacturing Capacity with Auto Rolling Forming Machinery

Street Lighting Poles

Electrical Construction Material Manufacturing Company , we have a hydraulic set up for cold reducing the pipe, we provide complete Lighting Solution to Industries, Textile ,Power house ,chemical sector ,Housing Societies, and Food industries complete solution with J bolts Panel

A L - F A Z A L - E N G I N E E R I N G

Tubular Double Arm

Can make any height any design

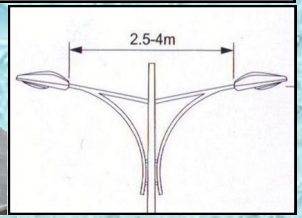
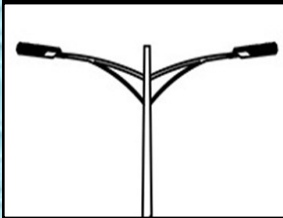

ALF-D-126

ALF-D-127

ALF-D-128

ALF-D-130

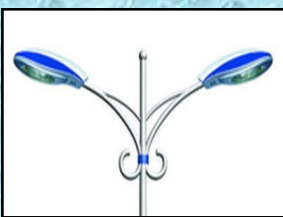

ALF-D-131

ALF-D-132

ALF-D-133

ALF-D-134

ALF-D-135

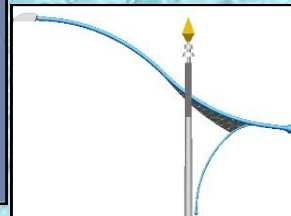

Tubular Single Arm

Can make any height any design

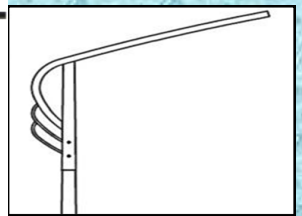
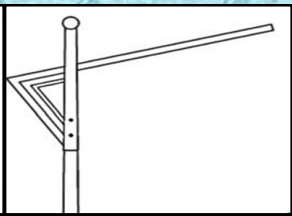
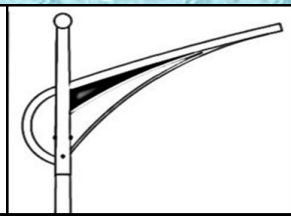
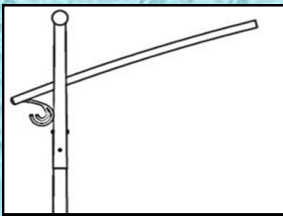

ALF-S-101

ALF-S-102

ALF-S-103

ALF-S-104

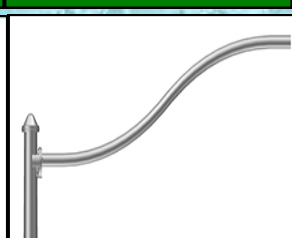
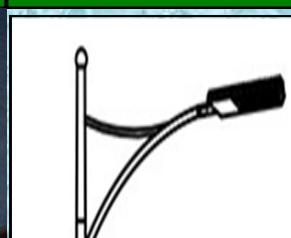

ALF-S-121

ALF-S-122

ALF-S-123

ALF-S-124

ALF-S-125

Pole Detail Sketch

8-Meter High Tubular Pole Hot Dip Galvanized Specification:

5" (OD 140mm) x 4.00mm Thk. = 3-Meter
 4" (OD 114mm) x 4.00mm Thk. = 2-Meter
 3" (OD 89mm) x 4.00mm Thk. = 2-Meter
 2" (OD 60mm) x 3.0mm Thk. = 1.5-Meter (With Arm)
 Arm Length = 500mm
 Base Plate = 400 x 400 x 16mm Thk.
 Stiffener = 100 x 260 x 16mm Thk.

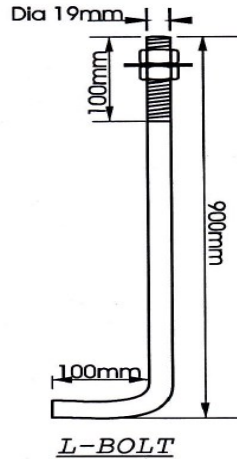
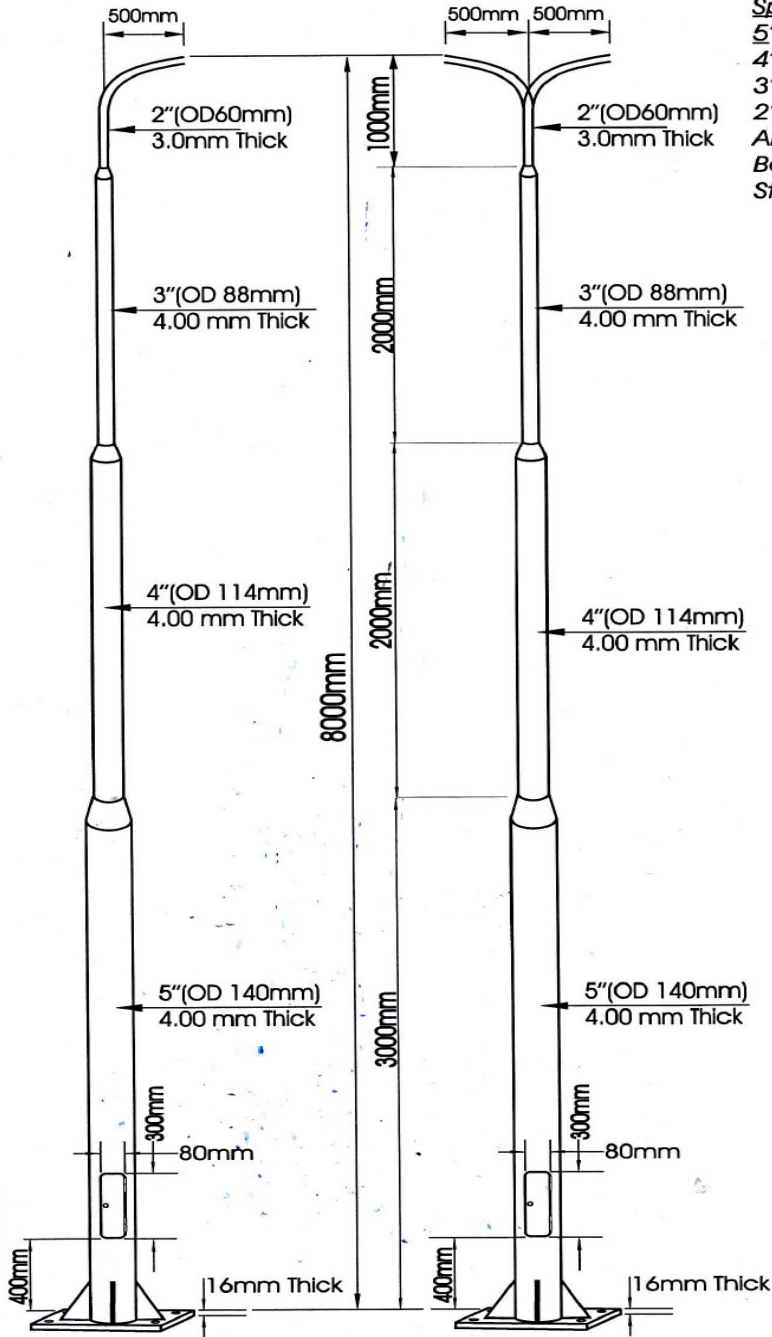

L-Bolt Set (4-Pcs)
 Dia = 19mm
 Length = 900mm
 Bend = 100mm
 with Double Nut & One Washer
 (Electroplating Galvanized)

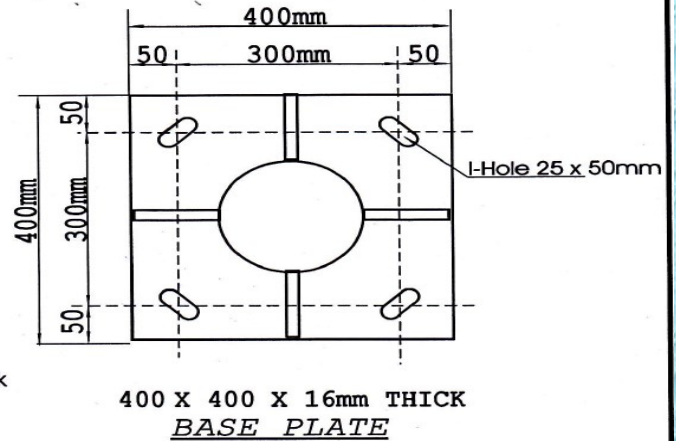
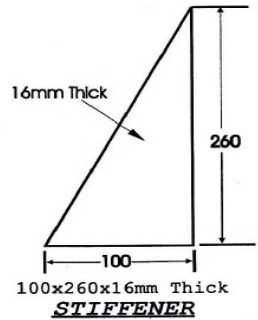

J Bolts and Templates.



Air Field Lighting

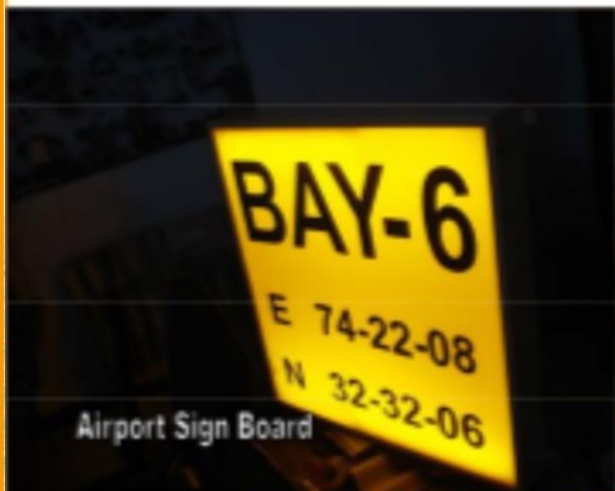

Cable Drum Jack and Rollers: we are manufacturer of cable laying accessories Like , Cable Drum Jack screw type , Hydraulic Jack , Different type of rollers , cable sock , MV /HV cable Clamps for Single Cables and Trefoil **Cables**.

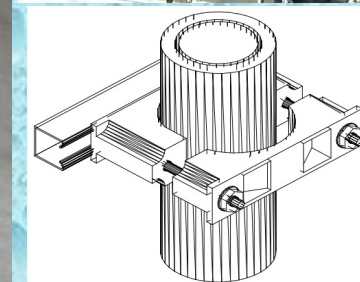

A
L
-
F
A
Z
A
L
-
E
N
G
I
N
E
E
R
I
N
G

Earthing Material Manufacturer:

we are manufacturer of Earthing Material , Rods , Clamps , Bus Bars
Test Point Links, Cad Welding Items , Pre cast Earth Pit .

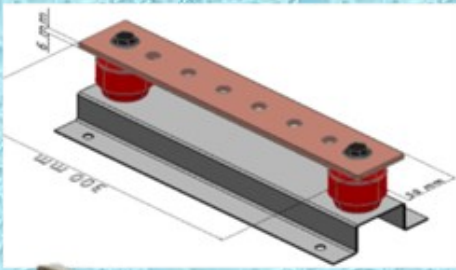

Cables and Cables Accessories

We are manufacturer supplier of cables and cable Accessories like Cable Glands (PVC / Brass / Explosion Proof EExde), Cable Lugs Cable Clamps, Non magnetic plates, SS and PVC Cable Tags, Cable Markers, Core Marking Sleeves ferrules, Reduces, Cable Termination Kits, HV / MV Cable camps, Trefoil Clamp, Underground Cable Markers, Cable Ties PVC SS, Caution Tape

AL-FAZAL-ENGINEERING

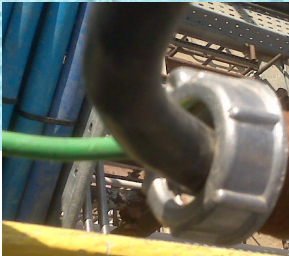

Steel Structure Tower & Steel Grating

we are manufacturer of Hot Dip Galvanized Steel Structure For Transformer MV HV Cables , Grid Station Equipment structure , Solar Structure , Steel Grating and clamps , Towers . Pole Overhead line etc

A
L
-
F
A
Z
A
L
-
E
N
G
I
N
E
E
R
I
N
G

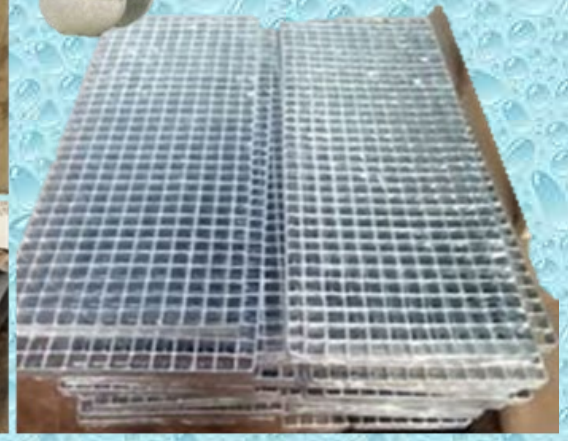

Panel DB Distribution Board JB,s

We are Manufacturer of LT Panels Lighting Distribution boards with auto ON / OFF control circuit in door out door type, ATS Panels , Battery Chargers Solar Combiner, Bus Bars Marshaling Panels, Auto Manual Change Over Panels, Junction Box weather proof ,CP System Panels, Lighting pole Junction Boxes. Services Provided for MV Panels installation Testing.



SIEMENS

Approved Partner
Industry, Automation and
Drive Technology

Authorized Dealer In Pakistan
Authentic / Reliable Source of Siemens
Original Products in Pakistan.

A
L
-
F
A
Z
A
L
-
E
N
G
I
N
E
E
R
I
N
G



M/s. Al Fazal Engineering

is hereby certified as a Regional Designated Dealer for cooperation in marketing for selected Siemens products. It has fulfilled the required Key Performance Indicators, proved technical knowledge and experiences as well as gained references on the market for the following Siemens Digital Factory and Process Industries and Drives portfolio:

- Factory Automation DF FA
- Process Automation PD PA
- Control Products DF CP

This arrangement is valid up to September 30, 2018 and renewable on a yearly basis.

Karachi, 01st October 2017
Siemens (Pakistan) Engineering Company Limited.

Azfar Ahmed Saeed
Divisional Head DF and PD

Syed Muhammad Ahsan Ghazali
Controller PD & DF Divisions





ALFAZAL ENGINEERING

*Manufacturer of Electrical, Mechanical Construction Material
Services and General Order Supplier*

Message From Management

Al-Fazal Engineering is a major name in Electrical Construction Material Manufacturer since 2007, we built a strong reputation all over the Pakistan with quality services and products. I am proud to be a CEO of this successful organization which is dedicated to doing business while living up to our Business Principles by being transparent, honest and caring for individuals and society. Our brand slogan,

1- Changes for the Better

2- Quality & Reliability is our Business .

Focusing our efforts to maintaining quality and dedication to bring the best solution with these beliefs that client satisfaction is our goal and priority by maintaining the safe work practices.

Regards,
CEO

b.ahmad@alfazalengineering.com

Lahore Office Manufacturing.

Plot No.7 Rahim Buksh Road, Salamatpura Stop, Orange line train station,
G.T. Road Darogawala Lahore.

PTCL – 042 36530011, 042 36545229

Cell – 03028493823 , 03018294615

03248281942 , 03008507602

Email– sales@alfazalengineering.com

lhr@alfazalengineering.com

info@alfazalengineering.com

Karachi Office Manufacturing.

MC 211 Street No. 7 Green Town

Shahra-e-Faisal Near Jinnah Terminal

PTCL – 021 34572359 , 021 34589504

Cell– 0321 8445190 , 03208445184

03218281942 , 03018238402

Email– khi@alfazalengineering.com

sales2@alfazalengineering.com

sales3@alfazalengineering.com

www.alfazalengineering.com